

FLATWORK IRONING EQUIPMENT

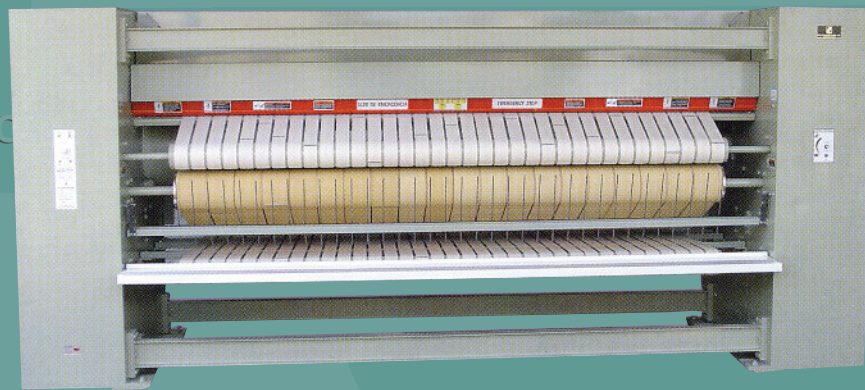

CMV SHARPER FINISH



FLATWORK IRONING EQUIPMENT

FLATWORK IRONING EQUIPMENT

HIGH CAPACITY IRONERS MODELS 3000 and 3600

“Some of over 100 model ironers we manufacture.”

FLATWORK IRONING EQUIPMENT

MODELS 3000 and 3600 FLATWORK IRONER

The **CMV Sharper Finish Model 3000** uses a full 30" (762mm) heated roll. The **Model 3600** uses a 36" (914mm) diameter heated roll. Both have oversized pressure rolls to produce outstanding quantity and exceptional quality of ironed flatwork.



The **Model 3000** provides 3,600 square inches (23,226 sq. cm) of heated ironing surface. The **Model 3600** has 4,320 square inches (27,864 sq. cm) of heated ironing surface.

Available gas or steam heated to meet your particular requirements. The most comprehensive safety and convenient features are standard equipment on both models.

The latest state of the art inverter drive provides totally variable speed throughout the

entire speed range plus provides dynamic braking as an added safety feature.

Silent induced draft burners, with 119 burner tips (120" / 3050 mm gas models), provide just the right amount of heat to properly dry and beautifully iron your flatwork but are not oversized to waste precious energy and money. Ignition of this burner is provided by direct spark in partnership with burner far-end flame sensor and ignition control module to insure safe and reliable operation.

**The Model 3000 can process anywhere from 200 to 400 sheets per hour*,
and the Model 3600 can process from 240 to 480 sheets per hour***

* Assuming rear delivery mode, and depending on moisture retention in the sheets. This includes the quality of the sheets, and the maximum G-force capability of your washer/extractor. It is assumed that the utilities and installation of the machine is correct. Pounds per hour is dependent solely on moisture retention and quality of linen. Please consult the factory to clarify production needs, or to help you with the 'sizing' of the machine.

INTELATROL® AUTOMATIC MONITORING SYSTEMS

We all need to be reminded of things from time to time. Have you ever forgotten to lock a door or turn off a light? Well, your laundry operator could forget to turn off the heat to your ironer, wasting energy and creating a hazard. They cannot forget if they have a CMV Sharper Finish ironer equipped with the Intelatrol. The Intelatrol will shut off the heat after twenty minutes if the machine is left unattended. A red light will indicate that the Intelatrol deactivated the system, thus saving energy, eliminating a potential hazard,

and greatly increasing 2 the life of your ironer ribbons, padding and covers. When the operator returns and pushes a switch to reset the Intelatrol, the heating system will be activated, and when ready to operate, a green light will indicate the CMV Sharper Finish is ready to begin ironing. Intelatrol II deactivates the drive system and the ironer stops. Intelatrol II is an automatic ironer shut off system which is standard on models 3000 and 3600. Intelatrol is only available on CMV ironers.

MODEL 3000/3600 SPECIFICATIONS

Heated Roll: Full 30" (762mm) diameter steel heated cylinder on **Model 3000** and 36" (914mm) diameter steel cylinder on **Model 3600**. The cylinder is accurately machined, ground, and polished to a mirror-like finish. 120" (3,048mm), width ((or optional 132" (3353 mm) and 136" (3454 mm) available)) to enable all standard flatwork items to be ironed. Cylinder is heated internally by gas or steam. Gas heated model may be heated by most types of gas. Steam heated model uses high-pressure steam of 100-150 P.S.I. (6.6-10 Bar).

Heating: Gas heated model equipped with full-length multi-port burner, with 119 burner tips, for maximum efficiency and even heat distribution. Heat is controlled by accurate snap action thermostat. Thermostat not required on steam heated models as heat is controlled by steam pressure provided by another source. Steam pressure gauge is standard equipment.

Automatic Heat and Energy Saver: Intelatroll is standard equipment on gas heated model. In the event no work is processed for a period of 20 minutes, the gas is automatically turned off. This saves energy and also reduces wear to covers, padding and other textiles. Should the machine be unattended for an additional 20 minutes the entire machine shuts down.

Pressure Rolls: Three oversize padded pressure rolls automatically apply the correct pressure to work being processed to produce an excellent finish on all types of normal flatwork.

Pressure Roll Padding and Covers: Pressure rolls are covered with heavy-duty heat resistant nomex padding and covers for long life and quality ironing.

Additional Ironing and Drying Capacity: Ironed work leaving the padded pressure rolls is automatically transferred to a series of heat resistant conveyor ribbons that hold the work in contact with the heated cylinder to provide additional drying, stretching, and increased production. A full 300° of the heated cylinder is utilized in the ironing and drying process.

Ironed Work Removed at Front or Rear: Ironed flatwork is automatically transferred to the delivery conveyor, which, simply by moving a switch (or the Simple life Delivery System), will deliver the work either to the rear of the machine, or to the front. This extreme flexibility is very useful in coping with various production requirements.

Totally Variable Speed: Totally variable speed of 30-85 feet per minute (6.1-30.5 m/min.) on **Model 3000** and 30-100 feet per minute (7.6-36.5 m/min.) on **Model 3600** is achieved through the use of the latest state of the art inverter drive. Dynamic braking assures quick, smooth stopping.

Drive System: Energy efficient drive motor coupled to oversize gear reduction unit by double "V" belts provides the initial driving power. Heavy-duty roller chains power the pressure rolls and conveyors.

Electrical Controls: All control circuits operate

at 24 volts to provide maximum safety. Each motor is equipped with individual magnetic starter with overload protection and is individually fused.

Ventilation System: Ventilating canopies extend the full width of the ironing surface and are connected to two powerful motor/blower units. Heat and moisture, generated by the ironing process, is removed and exhausted to the atmosphere. Heat from the inside of each end frame is also removed resulting in a cooler, more comfortable working area.

Safety Features: The following safety features are standard equipment:

- Full width safety guard stops machine when pushed at any point across feeding area.
- Safety cables at front and rear of machine stop machine when pushed or pulled.
- Drive end panel equipped with disconnect switch that must be off before door can be opened.
- Access panels interlocked to stop machine when opened.
- Canopies interlocked to stop machine when raised.
- Manual operating device provided so machine can be rotated in the event of a power failure.
- Bi-lingual warning and instruction labels.
- High pressure gas switch.
- High limit temperature switch.
- Safety poster and installation-operation video.
- Intelatroll II Safety Monitoring System
- Installation, operation, maintenance, service, venting manuals and video.

MODEL 3000/3600 TECHNICAL DATA

MACHINE MODEL ⇨	GR3000	GR3600	SR3000	SR3600
FINISHING SURFACE WIDTH - INCHES (mm)	120 (3050)**	120 (3050)**	120 (3050)**	120 (3050)**
HEATED ROLL DIAMETER - INCHES (mm)	30 (762)	36 (914)	30 (762)	36 (914)
VARIABLE SPEED RANGE - FEET/MINUTE (meters/minute)	30-85 FPM (6.1-30.5 m/min.)	30-100 FPM (7.6-36.5 m/min.)	30-85 FPM (6.1-30.5 m/min.)	30-100 FPM (7.6-36.5 m/min.)
ELECTRICAL REQUIREMENTS MOTOR H.P. (kW)	3 + 2 x 1 2.24 + 2 x .746*	3 + 2 x 1 2.24 + 2 x .746*	3 + 2 x 1 2.24 + 2 x .746*	3 + 2 x 1 2.24 + 2 x .746*
MAXIMUM GAS INPUT - B.T.U./HR. (CAL. Kg/h) Connection	495,000 (145) 1¼"	625,000 (183) 1½"	—	—
STEAM CONSUMPTION BOILER H.P. (kg/hr.) Connection	—	—	6.6 (108) 1½" in; ¾" out	8.0 (130) 1½" in; ¾" out
NET WEIGHT - POUNDS (kg)	7650 (3478)	9535 (4334)	8350 (3795)	9770 (4441)
CRATED SIZE L x W x H - INCHES (mm)	200 x 73.5 x 90 (5080 x 1867 x 2286)	212 x 82 x 97 (5232 x 2083 x 2464)	200 x 73.5 x 90 (5080 x 1867 x 2286)	212 x 82 x 97 (5232 x 2083 x 2464)
CRATED WEIGHT - POUNDS (kg)	8150 (3697)	10135 (4607)	8850 (3697)	10370 (4714)
CRATED VOLUME - CUBIC FEET (m³)	766 (21.7)	947 (26.8)	766 (21.7)	947 (26.8)

* (A worldwide variety of electrical specifications are available - consult factory.) ** (Optional 132" (3353 mm) and 136" (3454 mm) available.)

All **CMV SHARPER FINISH** ironers are manufactured to meet or exceed American National Standard Institute safety requirements (ANSI) for commercial laundry and dry cleaning operations. Steam heated ironers are built according to ASME standards, and meet or exceed the safety and testing requirements set by ANSI as stated above.

DIMENSIONS

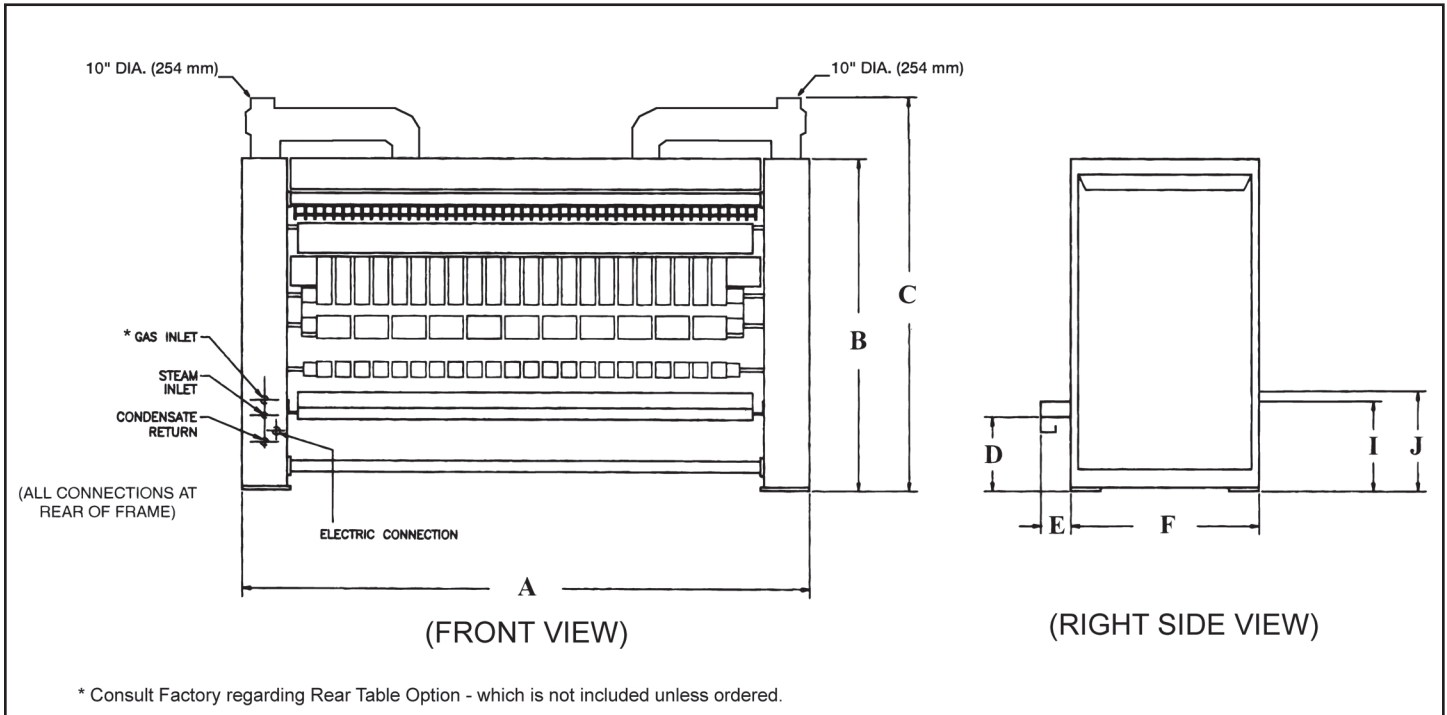

MODEL	A	B	C	D	E	F	I	J
3000 x 120" (3048)**	185" (4700 mm)	78" (1981mm)	96" (2438 mm)	23" (584 mm)	12" (305 mm)	49 ⁵ / ₈ " (1260 mm)	25" (635 mm)	29" (736 mm)
3600 x 120" (3048)**	191" (4851 mm)	82 ¹ / ₄ " (2089 mm)	101" (2565 mm)	25" (635 mm)	12" (305 mm)	58 ¹ / ₄ " (1480 mm)	21" (533 mm)	25" (635 mm)

** Also available in 132" (3353 mm) and 136" (3454 mm) ironing widths.

For a gas Model 3000, bring a 1½" gas line to the rear of the machine, then step down to 1¼" connection.

For a gas Model 3600, bring a 2" gas line to the rear of the machine, then step down to 1½" connection.

For steam models, the connections are 1" steam inlet; ¾" condensate return.

Distributed by:



CMV SHARPER FINISH, INC.

4500 AUGUSTA BLVD.

CHICAGO, ILLINOIS 60651-3399

CALL 773/276-4800 • FAX 773/276-6878

EMAIL: sales@cmvsharperfinish.com

www.ironerpeople.com



Designed AND Built
Right in The U.S.A.

Copyright 2015 by CMV Sharper Finish, Inc. Form No. 3036R3. In view of CMV's policy of providing you with the best products possible, we reserve the right to change specifications and appearance without notice. Contact the sales department for exact specifications, dimensions, and product approvals. We make over 100 different models that are sold throughout the world.