

# Hoffman

## Slim-Line Self-contained Press



*The new revolutionary design dry cleaning press.*

### **INNOVATIVE FEATURES:**

- Built-in ASME certified boiler
- Multiple boiler sizes available for connection to other equipment
- Built-in vacuum
- Available with an air operated or manual frame
- Reduced floor space
- Multiple head and buck shapes available
- Designed for easy maintenance

### **AVAILABLE OPTIONS:**

- Iron and lowboy system
- Swing-away sleeve board
- Water spray gun
- Automatic timer for air frame models
- ASME certified heads and bucks



SLUA-42SC



SLFX-42SC

The Hoffman logo, featuring a stylized 'H' with wings above it.

**HOFFMAN**

*The First Name In Pressing*

**TECHNICAL DATA:**

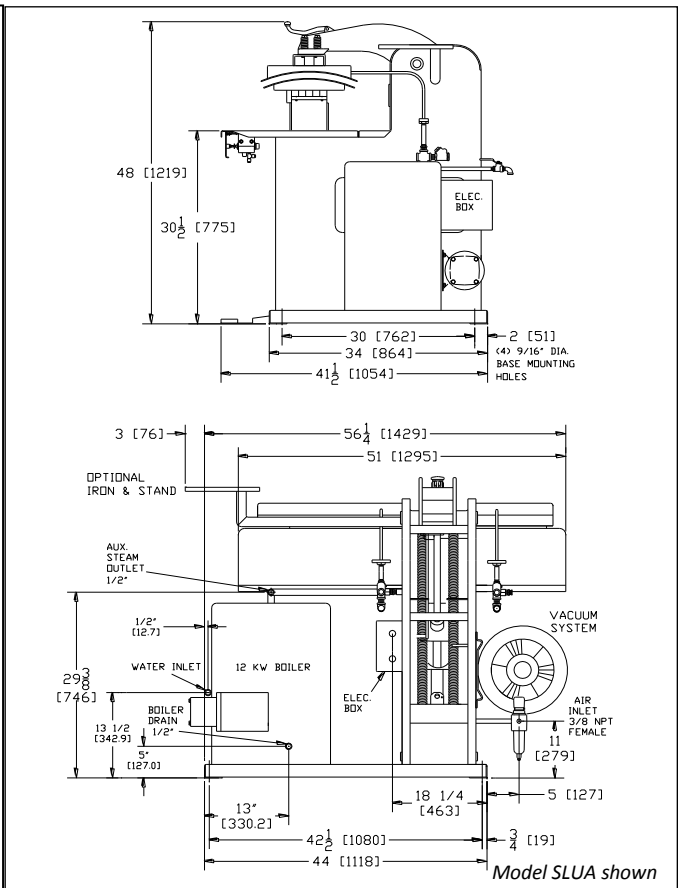
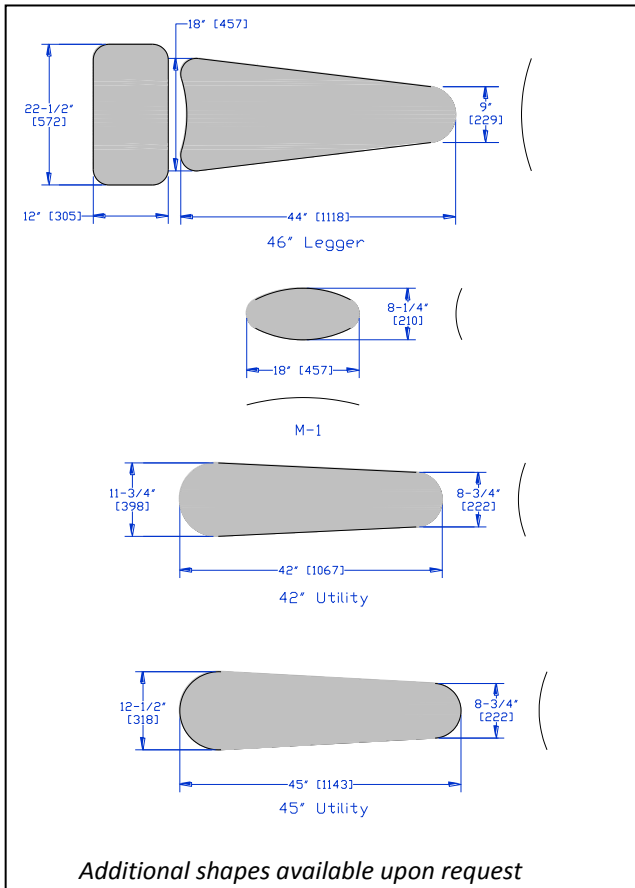

| <b>TECHNICAL SPECIFICATIONS:</b>   |  |   |  |   |
|--|--|---|--|---|
|  | <b>SLUA-42SC</b>                           | <b>SLFX-42SC</b>                            | <b>SLUA-45SC</b>                           | <b>SLFX-45SC</b>                            |
| <b>Steam Consumption @ 80 psig</b>   | 30 lb/hr [13.6 kg/hr]                      |   | 30 lb/hr [13.6 kg/hr]                      |   |
| <b>Max. Steam Pressure</b>   | 125 psi [862 KPa]                          |   | 125 psi [862 KPa]                          |   |
| <b>Air Consumption Free Air per Cycle @ 80 psi</b>                           | 0.69ft <sup>3</sup> [0.02 M <sup>3</sup> ] | 0.30ft <sup>3</sup> [0.008 M <sup>3</sup> ] | 0.69ft <sup>3</sup> [0.02 M <sup>3</sup> ] | 0.30ft <sup>3</sup> [0.008 M <sup>3</sup> ] |
| <b>Max. Air Pressure</b>   | 80 psi [552 KPa]                           |   | 80 psi [552 KPa]                           |   |
| <b>Vacuum Power</b>  | 1.5 HP [[1.1 kW]                           |   | 1.5 HP [[1.1 kW]                           |   |
| <b>Electrical - Boiler (12kW Standard)</b><br>18, 24, 30 & 36 also available | 208-220-240-380-480V<br>12-18-24-30-36 kW  |   | 208-220-240-380-480V<br>12-18-24-30-36 kW  |   |
| <b>Table Length</b>  | 51" [1295 mm]                              |   | 51" [1295 mm]                              |   |
| <b>Net Machine Weight</b>  | 1225 lb [556 kg]                           |   | 1235 lb [560 kg]                           |   |
| <b>Shipping Weight</b>   | 1325 lb [601 kg]                           |   | 1335 lb [606 kg]                           |   |
|  | <b>SLUAM-1SC</b>                           | <b>SLFXM-1SC</b>                            | <b>SLUA-46TSC</b>                          | <b>SLFX-46TSC</b>                           |
| <b>Steam Consumption @ 80 psig</b>   | 22 lb/hr [10 kg/hr]                        |   | 30 lb/hr [13.6 kg/hr]                      |   |
| <b>Max. Steam Pressure</b>   | 125 psi [862 KPa]                          |   | 125 psi [862 KPa]                          |   |
| <b>Air Consumption Free Air per Cycle @ 80 psi</b>                           | 0.69ft <sup>3</sup> [0.02 M <sup>3</sup> ] | 0.30ft <sup>3</sup> [0.008 M <sup>3</sup> ] | 0.69ft <sup>3</sup> [0.02 M <sup>3</sup> ] | 0.30ft <sup>3</sup> [0.008 M <sup>3</sup> ] |
| <b>Max. Air Pressure</b>   | 80 psi [552 KPa]                           |   | 80 psi [552 KPa]                           |   |
| <b>Vacuum Power</b>  | 1.5 HP [[1.1 kW]                           |   | 1.5 HP [[1.1 kW]                           |   |
| <b>Electrical - Boiler (12kW Standard)</b><br>18, 24, 30 & 36 also available | 208-220-240-380-480V<br>12-18-24-30-36 kW  |   | 208-220-240-380-480V<br>12-18-24-30-36 kW  |   |
| <b>Table Length</b>  | 56" [686 mm]                               |   | 56" [1219 mm]                              |   |
| <b>Net Machine Weight</b>  | 793 lb [360 kg]                            |   | 1304 lb [591 kg]                           |   |
| <b>Shipping Weight</b>   | 893 lb [405 kg]                            |   | 1404 lb [637 kg]                           |   |



**Hoffman/New Yorker, Inc.**  
 46 Clinton Place, Hackensack, NJ 07601  
 Tel: 201-488-1800 Fax: 201-488-4480  
[www.hoffman-newyorker.com](http://www.hoffman-newyorker.com)

**DISTRIBUTED BY:**

Equipment is subject to manufacturer's standard warranty. Accuracy of illustration and description of equipment shown herein applies to product.